

**W** White-Westinghouse

**INTERNATIONAL**

## Factory Parts Catalog

Product No.	WSPZ28V9CS1
Series	R134a System
Color	stain/blk
Volts	220
Wiring Diagram	240584001
Owner's Guide	240417300
Market	Export
Service Data Sheet	240588302

INTERNATIONAL  
3 Parkway Center, Pittsburgh, PA 15220

Publication No.  
**5995414751**  
04/08/10  
(EN/SERVICE/DCS)  
357

### **SIDE-BY-SIDE REFRIGERATOR**

Model No.  
**WSPZ28V9C**

Copyright © 2004 Electrolux Home Products, Inc.  
All rights reserved.

**FREEZER DOOR**

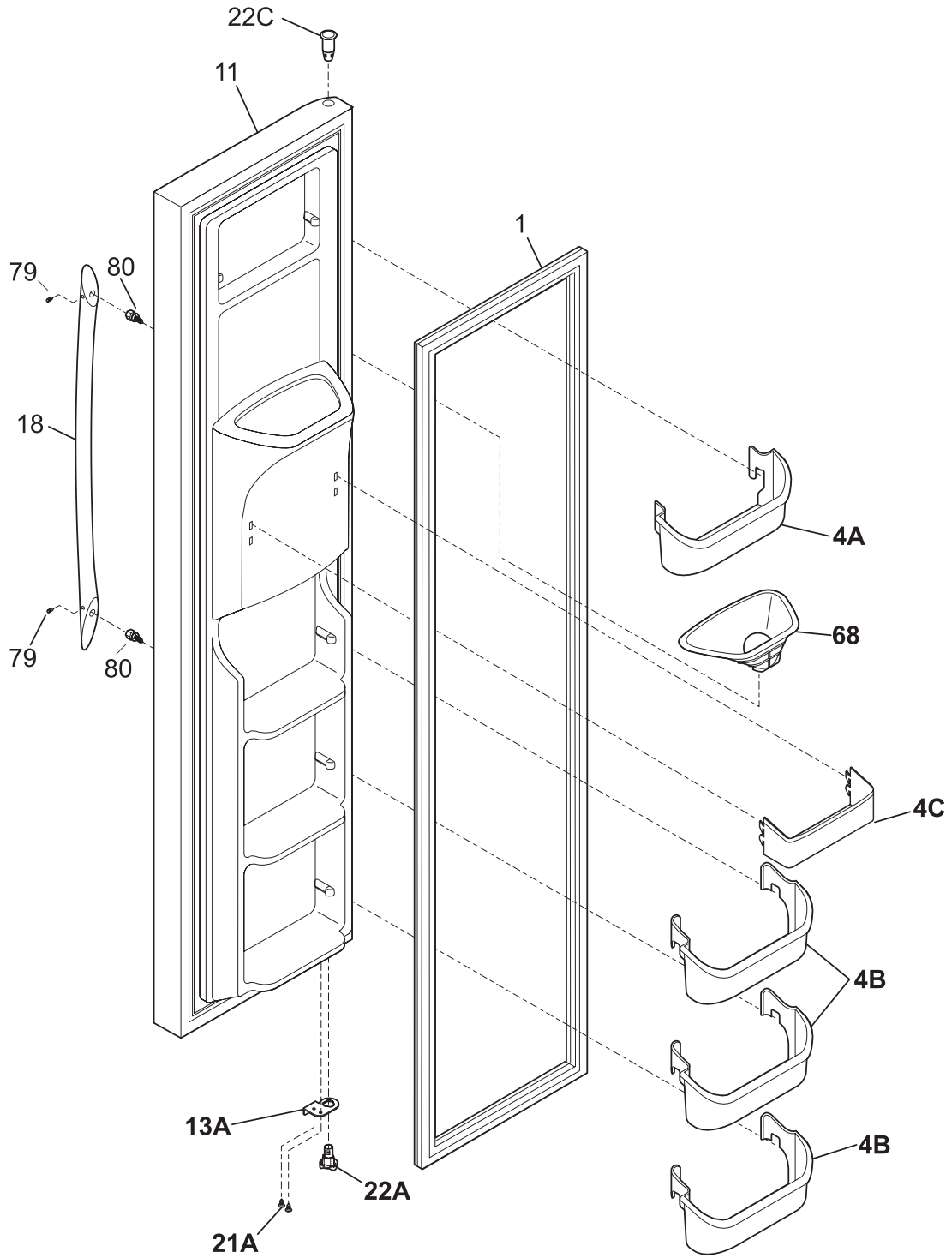

**N58FFDBAB1**

---

**FREEZER DOOR**

---

POS. NO	PART NO.	DESCRIPTION
1 #	240390606	Gasket-frzr door, black, magnetic
4A	240334205	Bin-door, frzr-upper
4B	240351605	Bin-door
4C	240351705	Bin-door, frzr-dispenser
11	240554273	Door-frzr, stainless, complete assy
13A	240581906	Door Stop, black, frzr
18	240536805	Handle-door, stainless steel, with insert, and set screw
21A	240598401	Screw, 10-32 x 1/2
22A	240328204	Bearing-hinge, closer
22C	240328404	Bearing-hinge, black, upper
68	241525101	Chute-ice
79	218755401	Screw-set, 10-32 x 0.375
80	218755503	Screw-shoulder, #10 AB, handle mounting
*	218490901	Cleaner, stainless steel
*	240352102	Connector-water, straight
*	240470401	Connector-amp
*	240552102	Harness-wiring, door
*	5303918273	Dispenser heater kit, 220

**REFRIGERATOR DOOR**

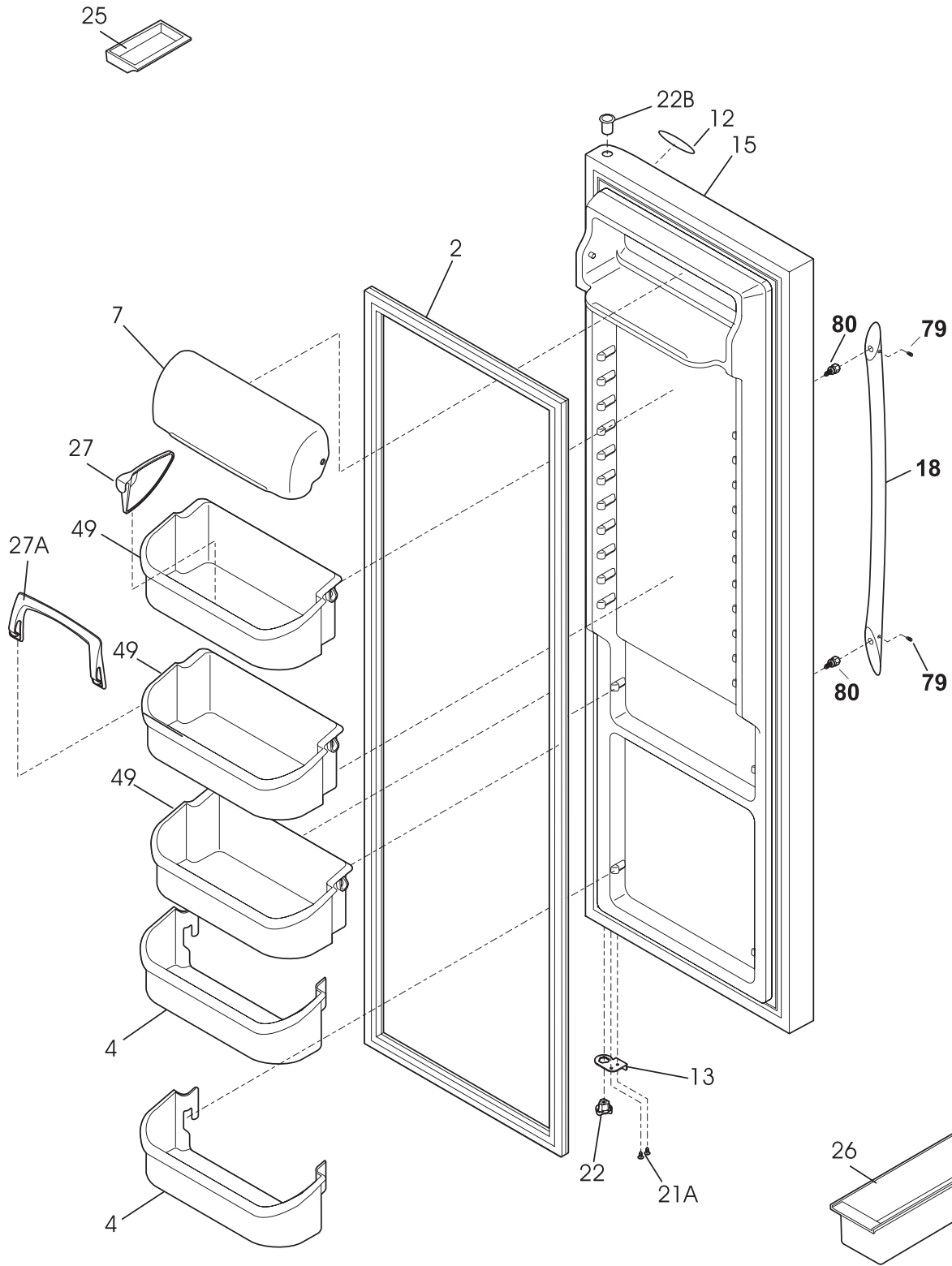

**N58RFDCAA0**

---

**REFRIGERATOR DOOR**

---

POS. NO	PART NO.	DESCRIPTION
2	240390605	Gasket-refr door, black, magnetic
4	240323005	Bin-door, pseudo, bottom
7	240326208	Door-dairy, clear
12	240578101	Label-nameplate
13	240581905	Door Stop, black, ref
15	240451984	Door-refr, stainless, complete assy
18	240536805	Handle-door, stainless steel, with insert, and set screw
21A	240598401	Screw, 10-32 x 1/2
22	240328203	Bearing-hinge, closer
22B	240328404	Bearing-hinge, black, upper
25	5308000716	Dish, butter
26	3204522	Container, egg
27	240396302	Snugger, paddle type
27A	240396102	Retainer, tall bottle
49	240356407	Bin-door, gallon
79	218755401	Screw-set, 10-32 x 0.375
80	218755503	Screw-shoulder, #10 AB, handle mounting
*	218490901	Cleaner, stainless steel

CABINET

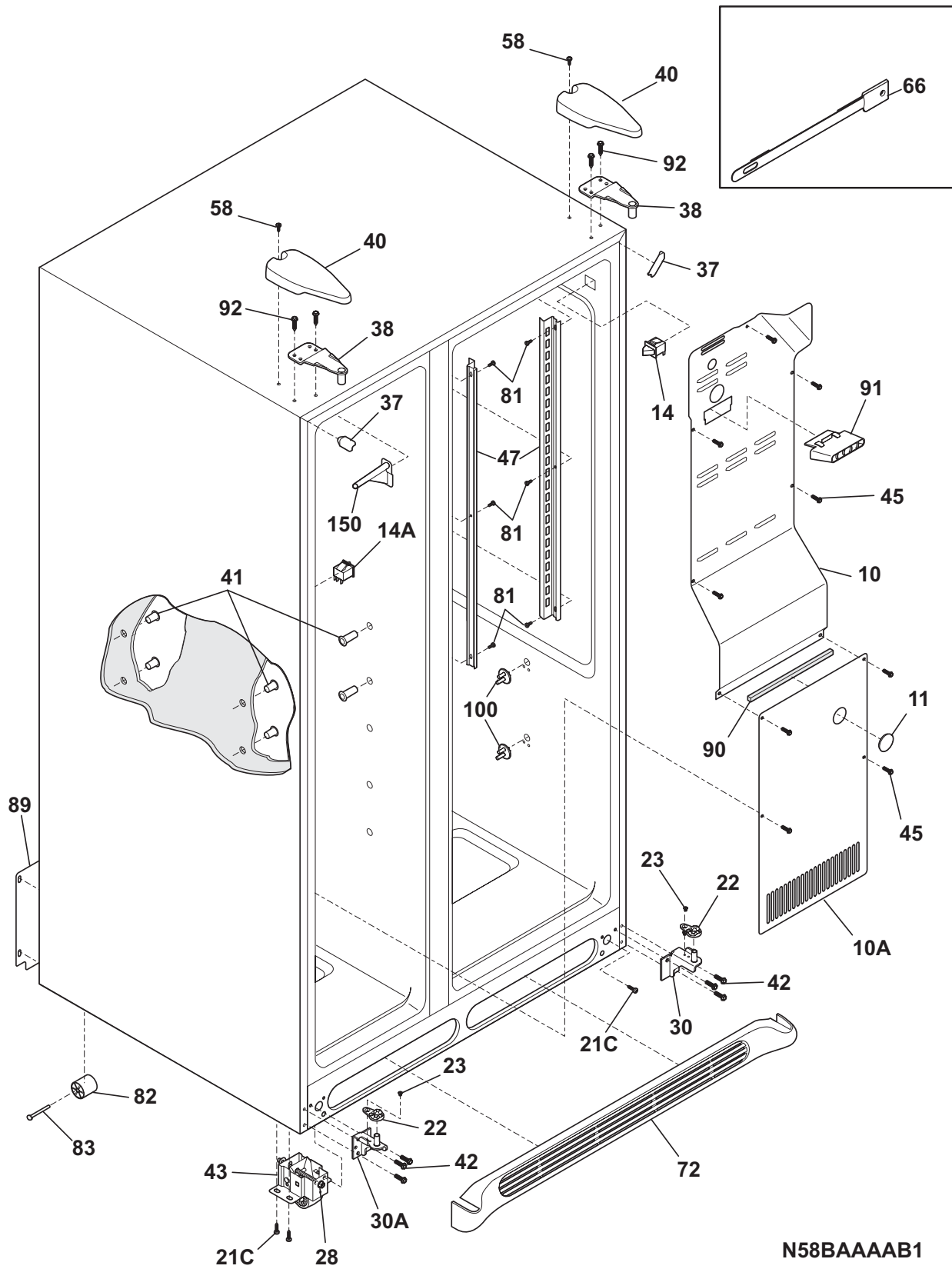

N58BAAAAB1

## CABINET

---

POS. NO	PART NO.	DESCRIPTION
10	240435906	Cover-air duct
10A	240475907	Cover-evap coil, lower
11	5303208309	Plug-hole, factory test
14	240505801	Switch, light/lamp
14A#	215486600	Switch-light/lamp
21C	218252200	Screw, #8 truss hd, 10-32CA x 0.500
22	240457702	Plate-door closer
23	240402701	Screw-#10-32 x 1/4 flat hd
28	240335501	Bolt-roller adj, hex washer head, 1/4-20 x 4.020, (2), special
30	240419101	Bracket-lower hinge, ref
30A	240419102	Bracket-lower hinge
37	240337603	Trim-cabinet corner, black, (2)
38	240327201	Bracket-upper hinge
40	240327007	Cover-upper hinge, black
41	241550801	Grommet-shelf mtg, 1.40" long
41*	241550701	Grommet-shelf mtg, .96" long
42	240578901	Screw-hinge mtg, hex head, 1/4-20 x 5/8
43	240335003	Roller Assy, front, (2)
45	241500301	Screw, hex washer head, 8-18AB x 0.500
47	240349402	Channel-shelf mtg, side, (2)
58	218781100	Screw, pan head, 8-18 x 0.625
66	5304424968	Damper Cover Assy
66*	240518802	Pin-push, push-in, plastic
72	240324406	Grille/Kickplate, black
81	5308016566	Screw, hex washer head, 8-15A x 0.625, low profile
82	5304418225	Roller, compressor base, rear, (2)
83	5303316859	Rivet, flat head, 1/4 OD x 1-3/4, roller pin
89	240326113	Cover-access, with label
90	218249808	Seal-coil cover
91	240380101	Duct-ice maker
92	216850900	Screw, hex washer hd, 1/4 x 7/8, hinge mtg
100	240423701	Support, crisper cover, front, (4)
100*	240350802	Support, crisper cover, rear, (4)
150	240368701	Guide-control bulb
*	240396801	Clamp, tube/wiring, nylon, black/natural
*	240479601	Plug, button, cab liner holes, (2)
*	240481601	Shim-lower hinge
*	5303305345	Paint, touch-up, black

**SHELVES**

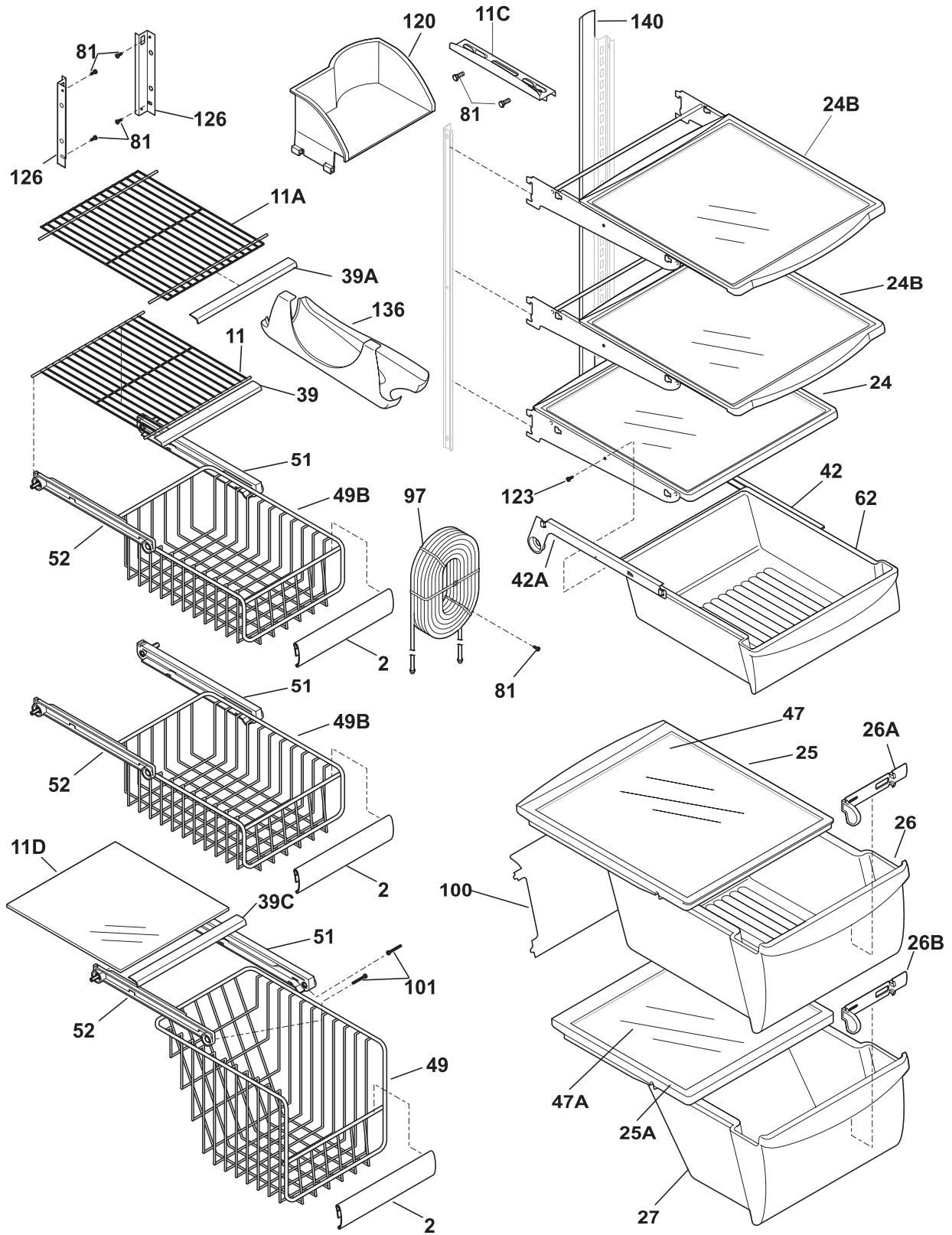

**N58SBEGBC1**



## SHELVES

---

POS. NO	PART NO.	DESCRIPTION
2	241510604	Trim-basket
11	240338802	Shelf-freezer, flip-up
11A	240338704	Shelf-freezer, fixed wire
11C	240324101	Shelf-pizza
11D	240350605	Shelf-freezer, glass, lower
24	240355235	Shelf-"Spill-Safe", fixed
24B	240350122	Shelf-"Spill-Safe", sliding, (3)
25	240350702	Cover-crisper pan, upper
25*	240362101	Clip-slide, cover-crisper
25A	240350902	Cover-crisper pan, lower
26	240351014	Pan-crisper, upper
26*	240349801	Clip-slide, pan-crisper
26*	240423101	Channel-divider
26*	240423203	Retainer, 26*
26*	240423303	Divider-crisper pan
26A	241552303	Control-humidity
26A*	241552403	Frame-humidity control, upper
26B	240362204	Control-humidity
27	240351212	Pan-crisper, lower
39	240430706	Trim-shelf, 11.21", front
39A	240430702	Trim-shelf, 12.39", front
39C	240367602	Trim-shelf, front
42	240356501	Track, meat pan hanger, RH
42A	240349701	Hanger-meat pan, LH
42A*	240349901	Block-meat pan rail, LH
42A*	240350001	Spring-meat pan rail
47	240443328	Insert-pan cover, glass
47A	240350603	Insert-pan cover, glass
49	240530402	Basket-sliding
49B	240530502	Basket-sliding, upper, half
51	240343002	Hanger-basket, RH
52	240343102	Hanger-basket, LH
62	240342811	Pan-meat
81	5308016566	Screw, hex washer head, 8-15A x 0.625, low profile
97	240545303	Water Tank Assy, coiled tubing, front filter
100	240326302	Cover-water tank
101	218493100	Screw, hex washer head, 8-18AB x 1-3/4
120	240342901	Shelf-ice cream
123	215005100	Screw, hanger/rlr mtg, 8-10 x 0.438
126	218867405	Channel, auger mtg, LH
126	218867406	Channel, auger mtg, RH
136	240424501	Dispenser-can, white
140	240430501	Channel, wtr tube cover

### CONTROLS

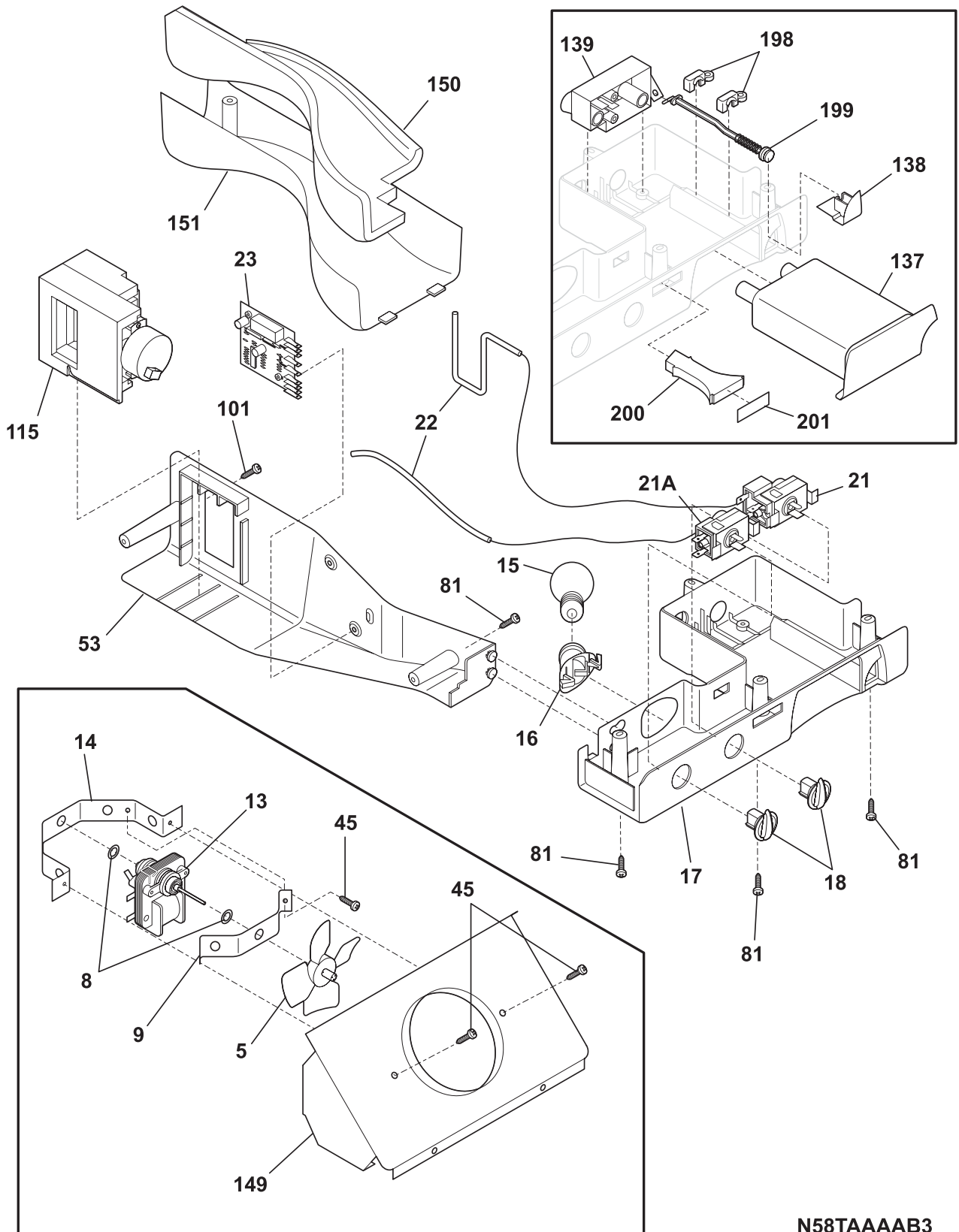

N58TAAAAB3

## CONTROLS

---

POS. NO	PART NO.	DESCRIPTION
5 #	5308000010	Fan Blade, red, evaporator fan
8	5300157666	Bushing-motor mtg, (2)
9	5303292396	Bracket-motor mtg, front
13 #	240419601	Motor-evap fan, 220V
13*	215474201	Washer, "slinger", nylon, evap fan shaft
14	5303292397	Bracket-motor mtg, rear
15	218814400	Light Bulb/Lamp
16	218971501	Socket-light/lamp
17	240317703	Box-control, front
17*	240439901	Wiring Harness, controls
18	240360801	Knob, temp control
21 #	241586502	Control-temperature
21A	5304432938	Control-temperature
22	218660702	Tube-insulator
23 #	240545404	Control-defrost, adaptive timer, 220/240 V, PC board
23*	5303001259	Screw-timer mtg, pan hd, 6-20 x 0.438, (2)
45	5303001343	Screw, hex washer head, 8-15A x 0.500
53	240369501	Box-control
81	5308016566	Screw, hex washer head, 8-15A x 0.625, low profile
101	218493100	Screw, hex washer head, 8-18AB x 1-3/4
115	240521108	Damper Assy, w/seal
137	240396404	Filter, water, front, with o'rings, cassette
137*	240396701	Bypass, water filter, Optional Part
138	240397301	Button-filter release
139	240396001	Base-water filter
139*	240526901	O-ring, wtr filter base
149	240331608	Shroud-fan orifice
150	240394204	Insulation-water tube cover
151	240373806	Cover-water tube
198	240397401	Retainer
199	240397501	Rod
199*	240398401	Spring-filter release rod
200	240397601	Light Pipe
201	240398506	Label-control box
*	3205266	Edge Protector, wiring harness
*	240410601	Shield-light, refr
*	240427202	Heater-freezer control
*	240470401	Connector-amp

**SYSTEM**

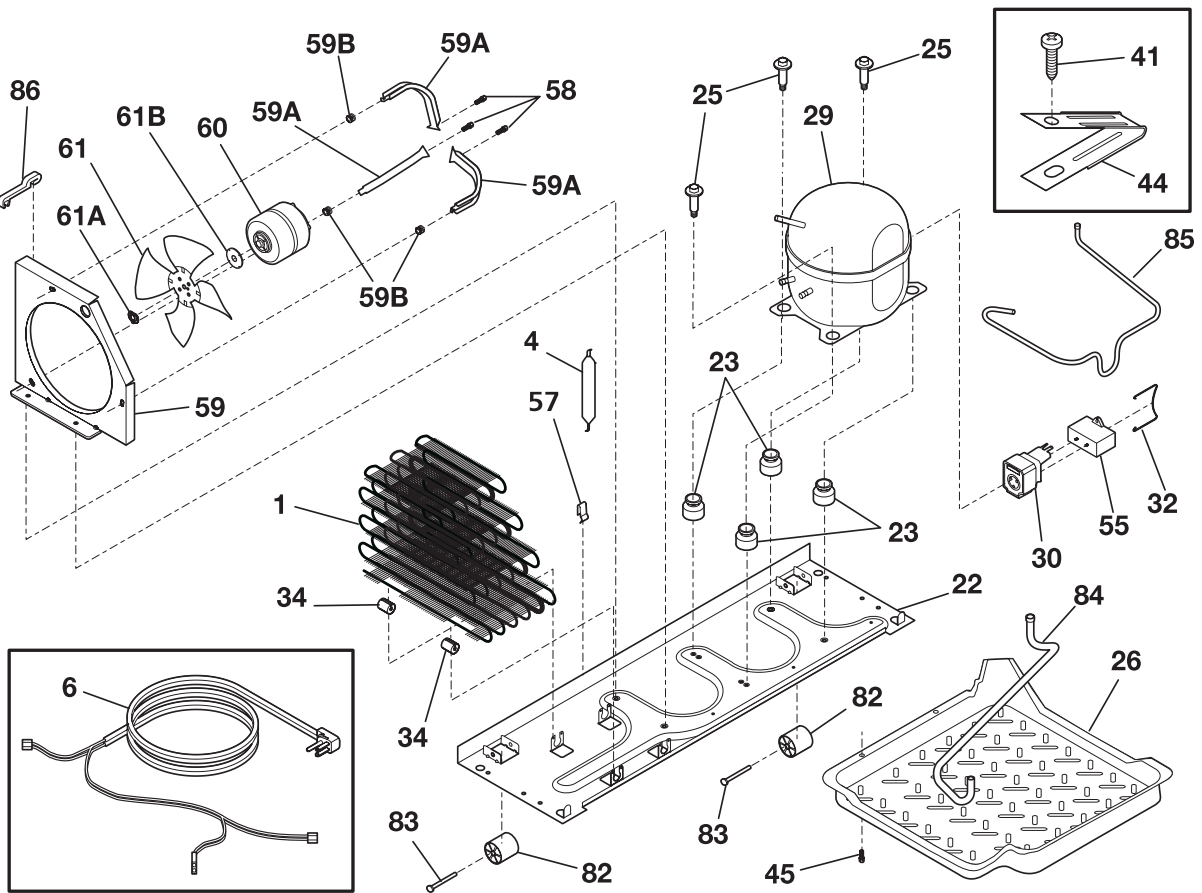
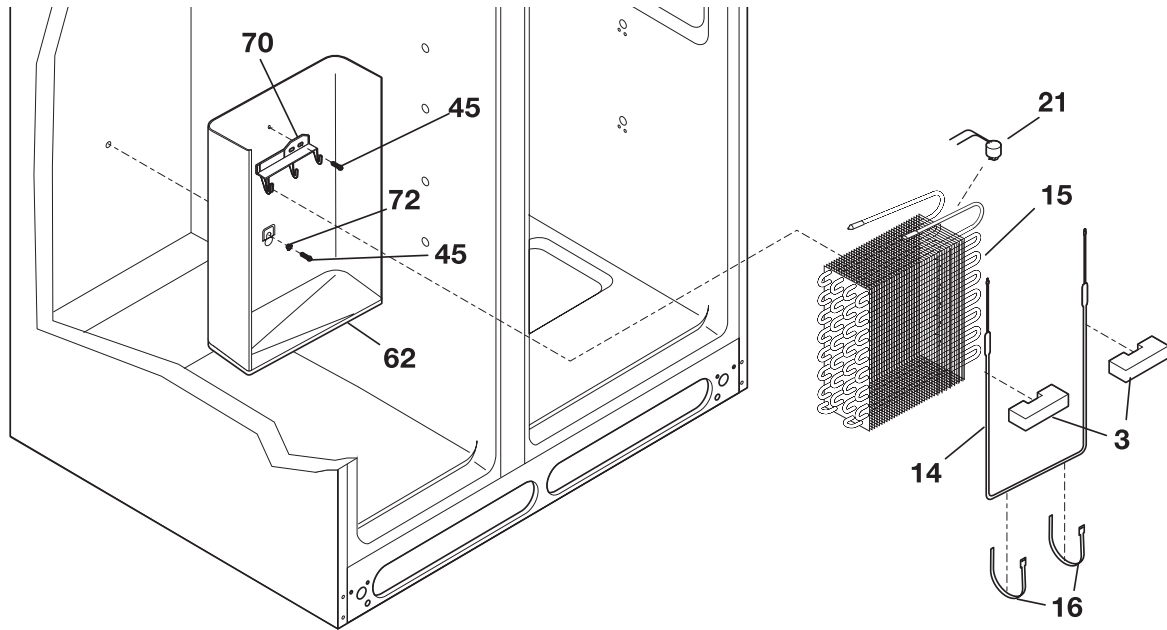

**N58CAAAA3**

---

**SYSTEM**

---

POS. NO	PART NO.	DESCRIPTION
1	240333603	Condenser
3	218679607	Block-evap coil, styrofoam, (2)
4 #	218944001	Drier-filter, R134a System
6	240449501	Cord-electric power
6*	240439901	Wiring Harness, controls
6*	240447101	Bracket, strain relief
6*	240447201	Clamp, strain relief
6*	240449601	Harness-wiring
6*	240451501	Screw, ind hex wshr hd, 8-32 x 0.375, thread rolling
6* #	240566701	Harness-wiring, machine compt
14 #	5303918245	Defrost Heater Kit, 220
15 #	5303918284	Evaporator Kit
16	5308000110	Strap-evap/heater, aluminum, (2)
21 #	5303918202	Thermostat-defrost, kit
22	240330008	Base-compressor mtg
22*	218252200	Screw, #8 truss hd, 10-32CA x 0.500
23	218513300	Grommet-compr mtg, (4)
25	240491501	Screw-compressor mtg, 1/4-28 x 1.16, shoulder, typ CF
26	240332602	Pan-defrost drain
29 #	5303918293	Compressor, w/electricals
30 #	218721121	Starter-PTC
32	240553401	Clamp, elec cont mtg, compressor
34	240405201	Grommet, rubber, black, cond tube/wire
41	240555001	Screw-#8-32 X 3/8
44	5303001199	Clamp-wiring harness, strain relief, galv steel
45	5308016566	Screw, hex washer head, 8-15A x 0.625, low profile
55 #	218909908	Capacitor, run
57	240542601	Clip-wiring harness
58	215004600	Screw, hx serr wshr hd, 8-36 x 7/16, cond fan motor, (2)
59	240315501	Shroud-cond fan
59*	240346701	Tape-foam seal, shroud
59*	240359401	Screw-fan shroud, (2)
59A	240346501	Bracket-support, cond mtr, (3)
59B	240346601	Grommet-bracket, (3)
60	240419801	Motor, condensor fan
61 #	240315401	Fan Blade, galv steel, condenser fan
61A	215004700	Nut, speed
61B	215004800	Grommet-silencer
62	240429402	Trough-drain
70	218990801	Bracket-evap/cvr mtg
72	218397000	Button-handle mtg, dovetail
82	5304418225	Roller, compressor base, rear, (2)
83	5303316859	Rivet, flat head, 1/4 OD x 1-3/4, roller pin
84	5304421068	Tube-drain, lower
85	240553501	Tube-connector, suction
86	240409302	Spacer-cond tube, black
*	5303918244	Hot Tube Repair Kit, Service
* #	5303918213	Heat Exchanger Kit, suction line

ICE & WATER DISPENSER

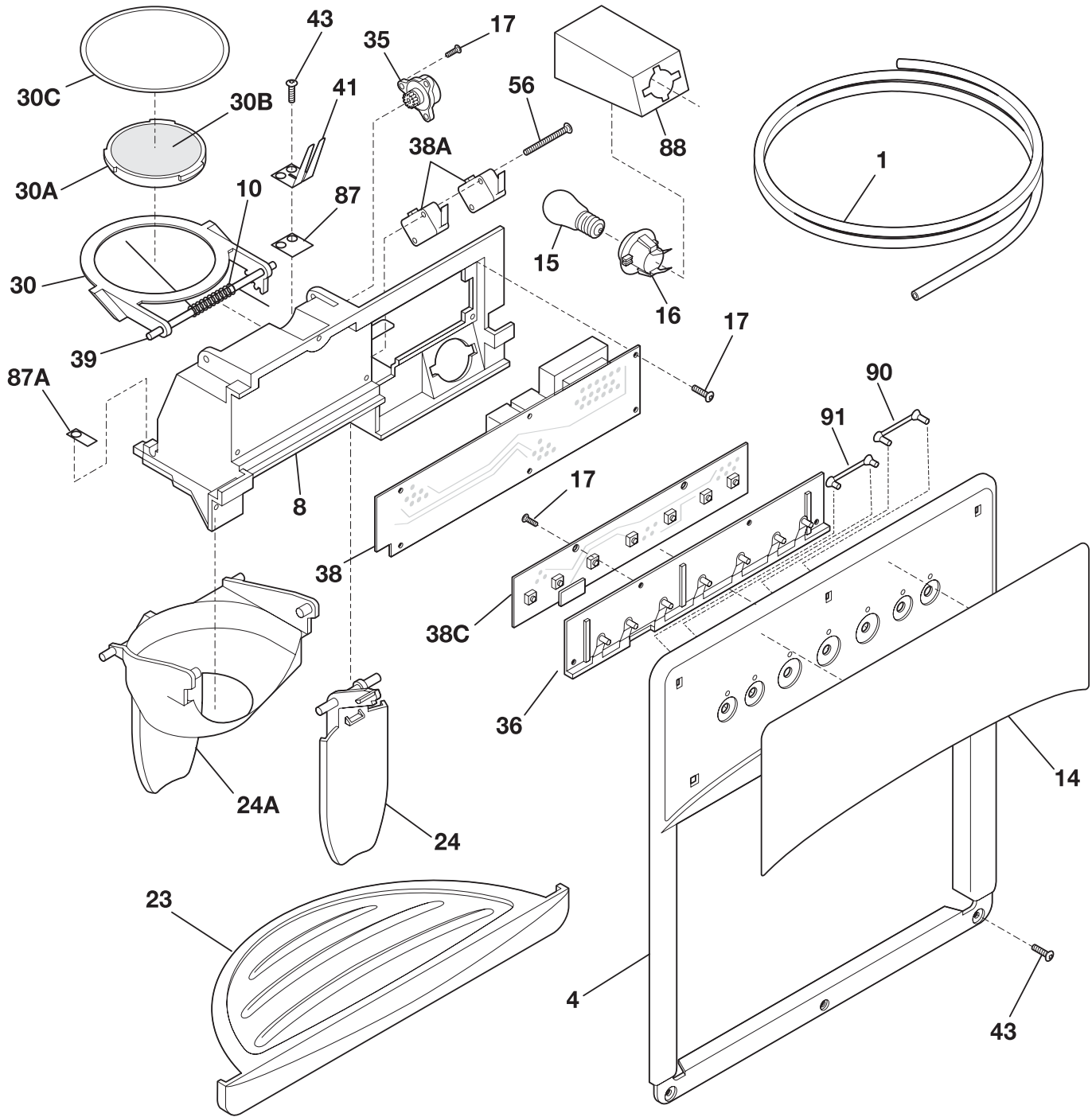

N58XBAAAB0

---

**ICE & WATER DISPENSER**

---

POS. NO	PART NO.	DESCRIPTION
1	218976409	Tube-water
1*	218976901	Tube-water inlet, inlet valve, to ice maker
1*	218976903	Tube-water inlet, inlet valve, to filter
1*	218976907	Tube-water inlet, valve to door
4	5304422012	Cover-module, black
8	5304422013	Module-dispenser
10	5304421626	Spring-torsion
14	240323932	Label-module cover, black
15	218557200	Light Bulb/Lamp
16 #	215621500	Receptacle, E-14 lampholder, 50/60 Hz, 250 V, IEC
17	5304421619	Screw
23	240323603	Drip Tray, black
24	5304422026	Actuator-water, black
24A	5304422025	Actuator-ice, black
30	5304421628	Door Assy-ice chute
30A	5304421624	Door center
30B	5304421625	Insulation-door
30C	5304421629	Door seal
35	5304421620	Damper-rotary
36	5304421824	Carrier
38	5304426548	Power Board
38A#	5304421617	Switch-micro, single pole, double throw
38C	5304426008	Board-control
38C*	218515401	Clip
39	5304421627	Pin-hinge
41	5304421829	Spring-actuator
43	215296300	Screw, plask h/l, #6 x 3/8
56	5304421830	Screw-micro switch, pan head
87	5304421622	Bearing Plate
87A	5304421621	Bearing Plate
88	5304421615	Shield-light
90	5304421831	Light Pipe, reflector
91	5304421850	Light Pipe, reflector, short
*	5303918273	Dispenser heater kit, 220
*	5304426535	Insulator-electrical

ICE CONTAINER

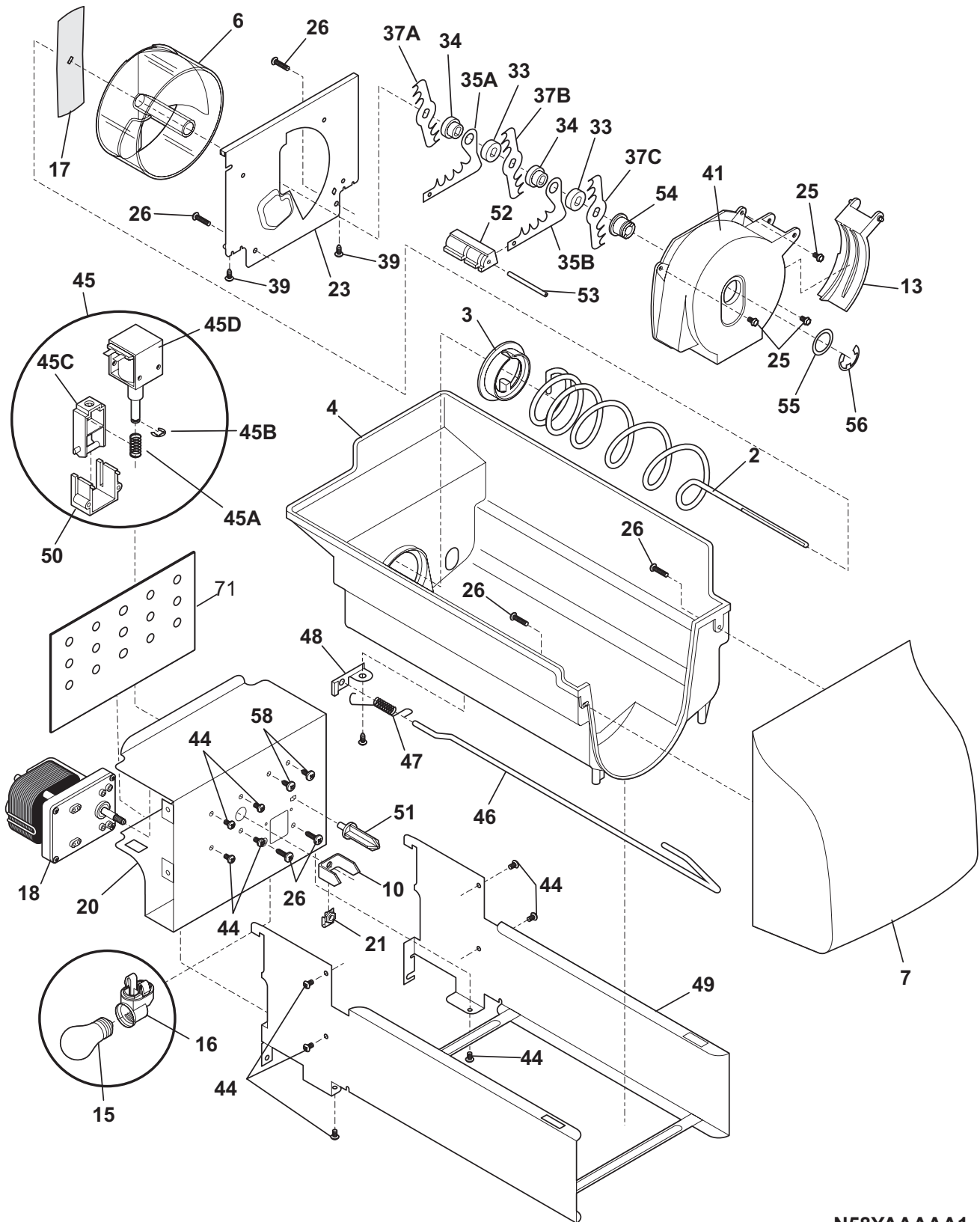

N58YAAAAA1



## ICE CONTAINER

POS. NO	PART NO.	DESCRIPTION
2	5304428402	Auger-ice
3	5304404343	Cam-drive
4	218815300	Container-ice, bucket only
6	5304404346	Drum-ice disp
7	5304422805	Front-ice container
10	5304404337	Bar-drive
13	5304404359	Gate
15	218814400	Light Bulb/Lamp
16	240433701	Receptacle, E27A lampholder, 115 V
17	5304404345	Drive Blade
18 #	5304441834	Motor-auger
18*#	240352601	Wiring Harness, internal, with plug
20	5304404332	Cover-motor
21	215285100	Nut-drive
23	5304404347	Plate-front
25	5304404362	Screw, hex washer head, 8-32T x 0.375
26	215503200	Screw, cr pan hd, 10-16 x 0.500
33	5304404351	Spacer
34	5304404349	Spacer
35A	5304404353	Fixed Blade, round
35B	5304404352	Fixed Blade, square
37A	5304404348	Blade, crusher #1
37B	5304404350	Blade, crusher #2
37C	5304404356	Blade, crusher #3
39	5304404365	Screw
41	5304404358	Housing-crusher
44	218359200	Screw, pan head, 8-32 x 0.250
45 #	5304406815	Solenoid Assy, 220 V
45A	5304406816	Spring-solenoid
45B	5304406817	E-Ring-solenoid
45C	5304406818	Actuator-solenoid
45D#	5304406820	Solenoid, 220 V
46	5304404341	Control Rod
47	5304404342	Spring-control rod
48	5304404340	Bracket-control rod
48*	5304404364	Screw-bracket
49	5304404329	Rail Assy
50	5304404334	Guide-solenoid
51	5304404336	Rotation Stop
52	5304404354	Spacer-fixed blades
53	5304404355	Pin-spiral, fixed blades
54	5304404357	Nut-auger
55	5304404360	Washer
56	5304404361	E-ring
58	5304404331	Screw-solenoid
71	241577302	Cover-Rear Auger
*	240323806	Ice Container Assy, w/moving parts
*	218817301	Shield-light
*	5303001343	Screw, hex washer head, 8-15A x 0.500

**ICE MAKER**

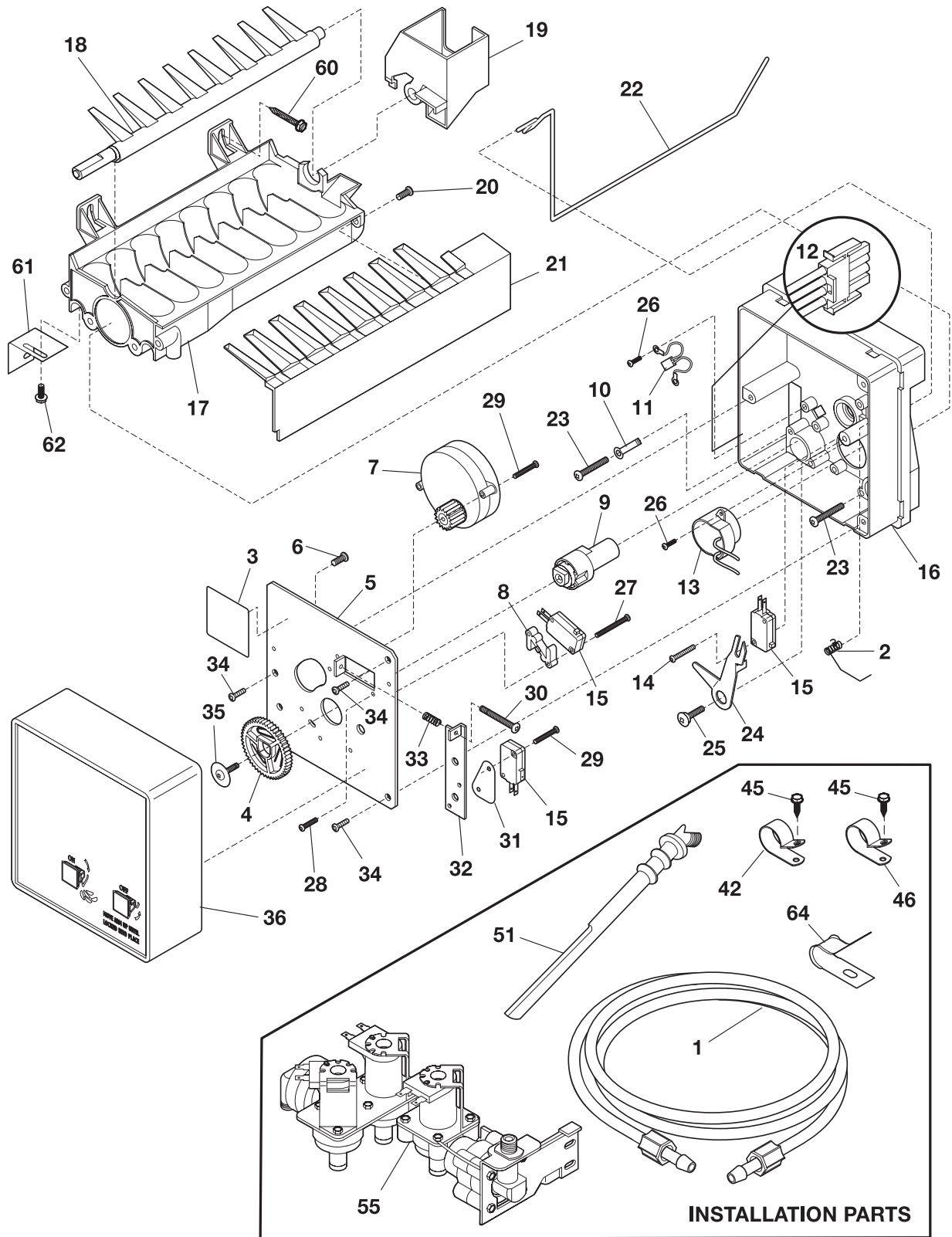

N58I115

## ICE MAKER

POS. NO	PART NO.	DESCRIPTION
1	218976409	Tube-water
1*	218976901	Tube-water inlet, inlet valve, to ice maker
1*	218976903	Tube-water inlet, inlet valve, to filter
1*	218976907	Tube-water inlet, valve to door
1*	240561701	Seal-water inlet, inlet valve, to ice maker
2	5304420650	Spring, shut-off arm
3	5303210334	Plate-I.D.
4	3206301	Gear
5	3206303	Plate-mounting
6	3206305	Screw-ground wire, 8-32 x 0.250
7 #	5303210332	Motor-ice maker
8	3206312	Spacer-hold switch
9	3206313	Cam
10	3206315	Clamp
11 #	3206319	Thermal Cutoff, ICE MAKER, complete assy
12 #	240352601	Wiring Harness, internal, with plug
13 #	3206322	Thermostat Assy, ICE MAKER
14	5304420652	Screw, 4 x 0.750, switch mtg.
15 #	3206324	Switch, (3)
16	5304420653	Support, phenolic
17 #	5304420711	Mold-ice maker, Radius Cube, 220V, with heater
18	3206328	Ejector-ice
19	5304408580	Cup-water inlet, w/bearing
20	5304408581	Screw, 8-32 x 0.375
21	3206332	Ice Stripper
22	3206333	Shut-off Arm
23	5304408582	Screw, 8-32 x 0.875, mold-to-support, (3)
24	3206335	Lever Arm
25	3206336	Screw, 8-18 x 0.562, lever arm/sprt
26	5304420654	Screw-thermo/sprt, 4-24 x 0.375, (4)
27	3206338	Screw, 4-40 x 1.000, hold switch mtg, (2)
28	3206339	Screw-timing stop, 4-40 x 0.375
29	3206323	Screw, 4-24 x 0.750, (6)
30	3206341	Screw-timing adj, 8-32 x 1.000
31	3206342	Insulator
32	3206343	Plate-valve switch
33	5304408583	Spring-timing adj
34	5304420655	Screw, plazscrew, 8-10, (3)
35	5304408585	Screw
36	3206347	Cover-ice maker
42	5303001199	Clamp-wiring harness, strain relief, galv steel
42*	218515402	Clip, (2), tube mtg.
45	5303001343	Screw, hex washer head, 8-15A x 0.500
45*	5308016566	Screw, hex washer head, 8-15A x 0.625, low profile
46	5308000133	Clamp, nylon, .625 ID
51	240387101	Tube-water, ice mold fill, extension
55	240536201	Valve-water, triple solenoid, 220
55*	218709100	Screw, hex head, 10-32 x 0.500
55*	240363601	Screw-shoulder
55*	240542901	Cap-water valve
60	5303207328	Screw, hex washer head, 8-15A x 1.000, (2)
61	218721500	Bracket-leveling, ICE MAKER
62	218737900	Screw-IM brkt mtg, hex washer head, 8-32D x 0.375
64	5303001549	Clamp, 0.31 ID, steel, copper wtr line
*	218888001	Adapter-water supply, nut & sleeve, compression ftg
*	240352412	Ice Maker, Radius Cube, 220 V, no instl parts
*	5308000247	Saddle Valve Kit

### WIRING SCHEMATIC

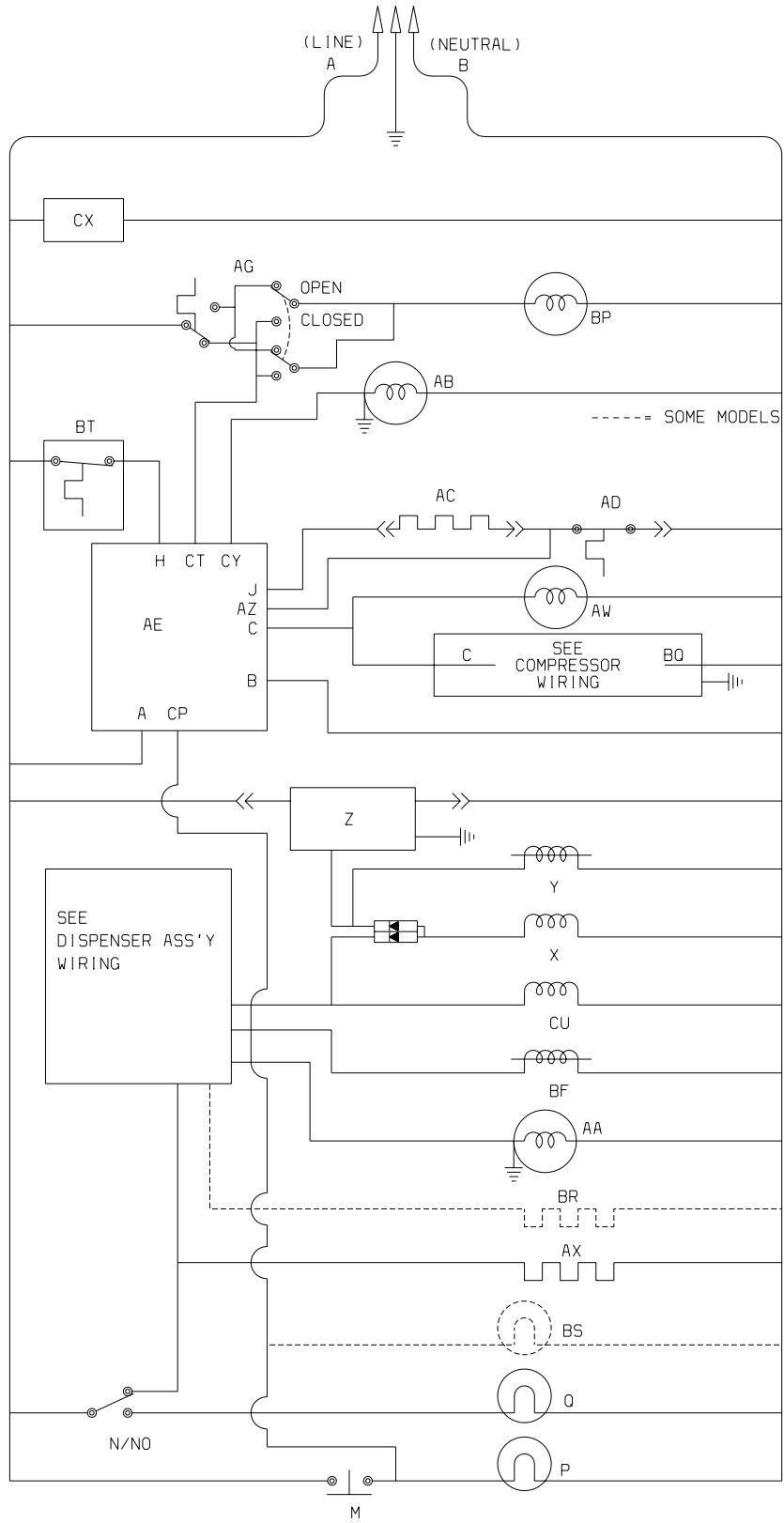

WIRING DIAGRAM

